

HIGH-PERFORMANCE BUTTERFLY VALVE HP 114-E



Lug type butterfly valve in double-eccentric construction. Reliable sealing even with extreme temperature and pressure conditions.

TECHNICAL DATA

Nominal diameter:	DN 50 – DN 200 larger nominal diameter on request
Face-to-face:	EN 558 Series 20 (DIN 3202 T3 K1) ISO 5752 Series 20 (DIN 3202 T3 K1) API 609 Table 1 BS 5155 Series 4 NF E 29-305.1
Flange accommodation:	DIN 2501 PN 10/16 DIN 2632/33 ANSI B 16.5, Class 150 AWWA C 207 AS 2129 Table D and E BS 10 Table D and E JIS B 2211-5 K JIS 2212-10 K
Flange Surface Design:	DIN 2526, Form A-E, ANSI RF
Top flange:	EN ISO 5211 NF E 29-402
Marking:	DIN EN 19
Tightness check:	
- for R-PTFE Sitz:	DIN 3230-BO (Leakage Rate 1)
- for Inconel Sitz:	DIN 3230-BN (Leakage Rate 1) ISO 5208, Category 3 API 598 Table 5 ANSI B 16-104, Class VI
Temperature range:	-196 °C to + 550 °C higher temperatures on request
Differential pressure:	see Pressure/Temp. Diagram
Vacuum:	>10 ⁻² mbar

FEATURES

- Shut-off and control of gaseous and liquid media
- Disc and shaft have double-eccentric bearing
- Two seat ring systems available: R-PTFE and Inconel-FS
- Seal variants:
soft-sealing (R-PTFE) 230 °C max.
metallic sealing (Inconel) 550 °C max.
- Maintenance-free
- Long service life, even at high switching frequencies
- FIRE SAFE BS 6755 PART 2

GENERAL APPLICATIONS

- Chemical and petrochemical industries
- Hot water and steam systems
- District heat supply
- Vacuum systems
- Shipbuilding
- Gas process technology
- Food industries
- Heavy duty services

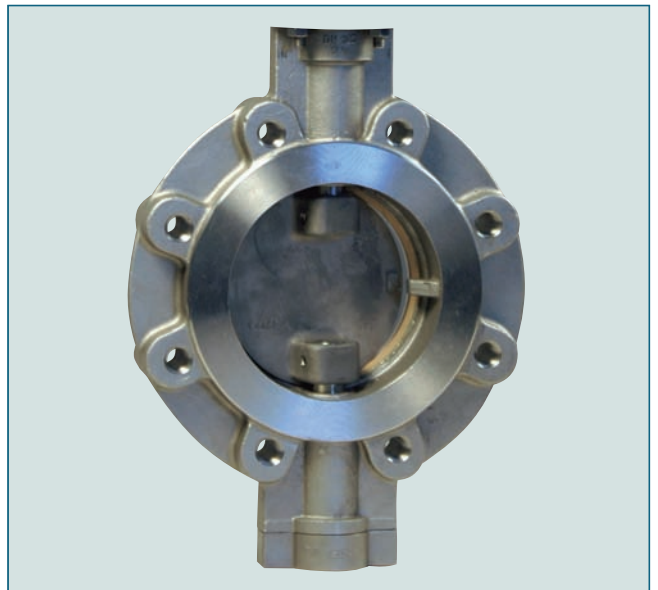

The splitted shaft design allows better flow characteristics up to a nominal pressure of 19 bar.

HIGH-PERFORMANCE BUTTERFLY VALVE HP 114-E

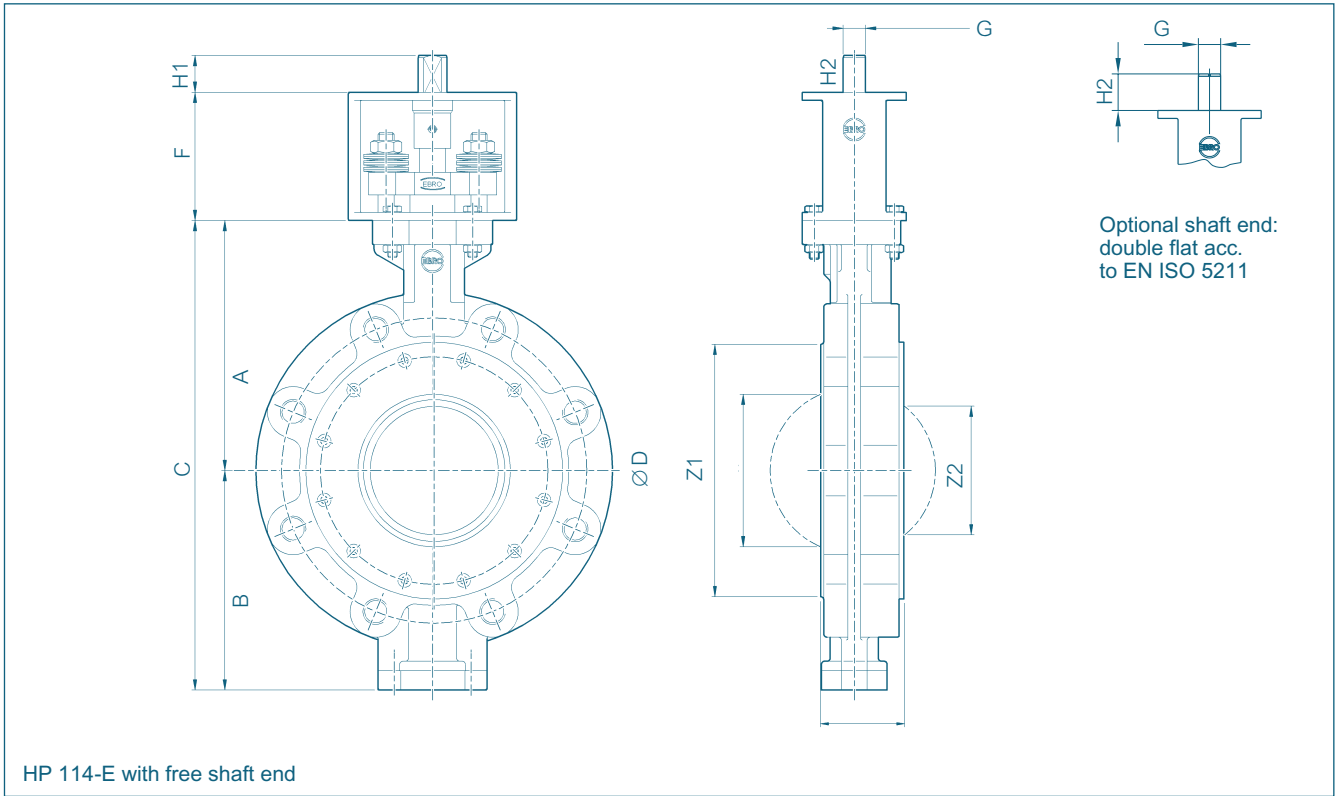

Optional shaft end:
double flat acc.
to EN ISO 5211

DN [mm]	Size [in]	Dimensions [mm]										min. Pipe-Ø	Weight [kg]			
		A	B	C	D	E	F	Flange	□G	H1	G			H2	Z1	Z2
50	2	131	112	243	122	43	80	F05	12	15	14	23	41	-	51	8,4
65	2½	131	112	243	122	43	80	F05	12	15	14	23	41	-	51	8,4
80	3	141	122	263	138	46	80	F05	12	15	14	23	71	55	80	9,7
100	4	156	137	293	158	52	80	F05	12	15	14	23	95	82	103	11,8
125	5	180	172	352	186	56	80	F07	14	18	17	28	115	106	124	16,8
150	6	194	186	380	216	56	80	F07	14	18	17	28	144	136	151	21,8
200	8	219	212	431	270	60	80	F10	17	18	22	37	188	182	196	33,6

Subject to change without notice.

ACTUATORS HP 114-E

WORM GEAR FOR PTFE-SEAT

DN [mm]	Size [in]	Gear	H	J	K	L	Weight [kg]
50-125	2-5	Size II	89	39	125	159	1,4
150	6	Size III	129	47	200	202	2,3
200	8	Size IV	129	60	200	252	2,8

FOR INCONEL-SEAT

DN [mm]	Size [in]	Gear	H	J	K	L	Weight [kg]
50-100	2-4	Size II	89	39	125	159	1,4
125-150	5-6	Size III	129	47	200	202	2,3
200	8	Size IV	158	76	250	280	6,3

The dimensioning of actuators refers to an operating pressure of 10 bar.

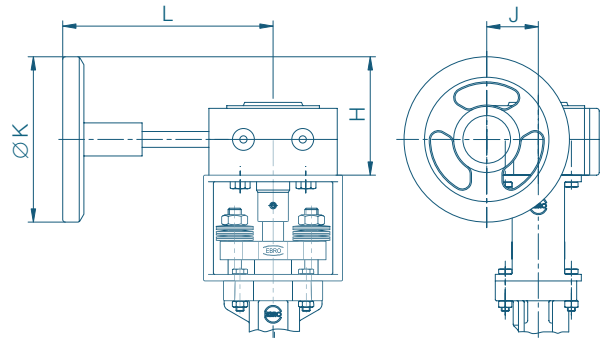

ELECTRIC ACTUATOR FOR PTFE-SEAT

DN [mm]	Size [in]	Actuator Type	H	J	K	L	M	Weight [kg]
50-125	2-5	E 65	233	172	80	139	119	7,0
150-200	6-8	E 110	251	245	125	139	134	14,0

FOR INCONEL-SEAT

DN [mm]	Size [in]	Actuator Type	H	J	K	L	M	Weight [kg]
50-100	2-4	E 65	233	172	80	139	119	7,0
125-200	5-8	E 110	251	245	125	139	134	14,0

The dimensioning of actuators refers to an operating pressure of 10 bar.

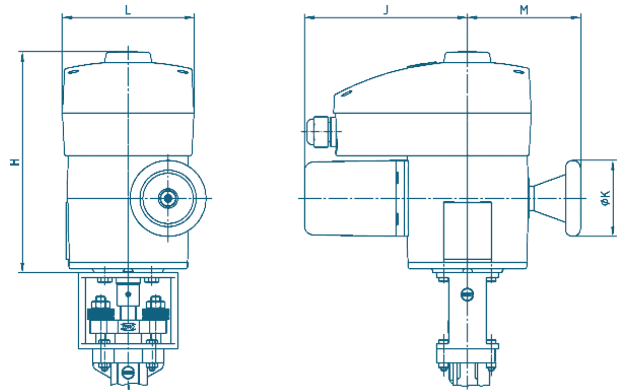

Subject to change without notice.

ACTUATORS HP 114-E

PNEUMATIC DOUBLE ACTING FOR PTFE-SEAT

DN [mm]	Size [in]	Actuator Type	H	J	K	L	Weight [kg]
50-100	2-4	EB 5	108	88	55	174	1,7
125-150	5-6	EB 6	123	103	62	208	2,6
200	8	EB 8	136	115	68	250	4,3

FOR INCONEL-SEAT

DN [mm]	Size [in]	Actuator Type	H	J	K	L	Weight [kg]
50-80	2-3	EB 6	108	88	55	174	1,7
100	4	EB 6	123	103	62	208	2,6
125-150	5-6	EB 8	136	115	68	250	4,3
200	8	EB 10	155	135	79	312	6,8

The dimensioning of actuators refers to an operating pressure of 10 bar and a control air pressure of 6 bar.

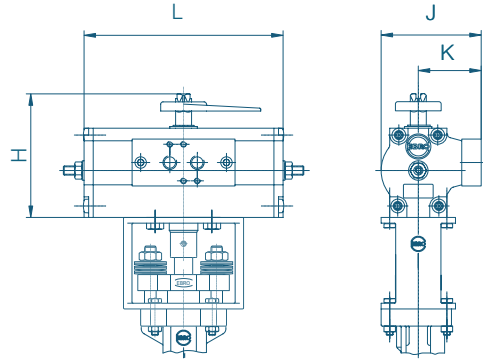

PNEUMATIC SPRING RETURN FOR PTFE-SEAT

DN [mm]	Size [in]	EBF Actuator	H	J	K	L	Weight [kg]
50-80	2-3	EB 5	108	88	55	273	3,0
100	4	EB 6	123	103	62	326	5,0
125	5	EB 8	136	115	68	389	7,7
150	6	EB 10	155	135	79	526	14,3
200	8	EB 12	182	159	94	656	25,4

FOR INCONEL-SEAT

DN [mm]	Size [in]	EBF Actuator	H	J	K	L	Weight [kg]
50-80	2-3	EB 8	123	103	62	326	5,0
100	4	EB 8	136	115	68	389	7,7
125-150	5-6	EB 10	155	135	79	526	14,3
200	8	EB 12	182	159	94	656	25,4

The dimensioning of actuators refers to an operating pressure of 10 bar and a control air pressure of 6 bar.

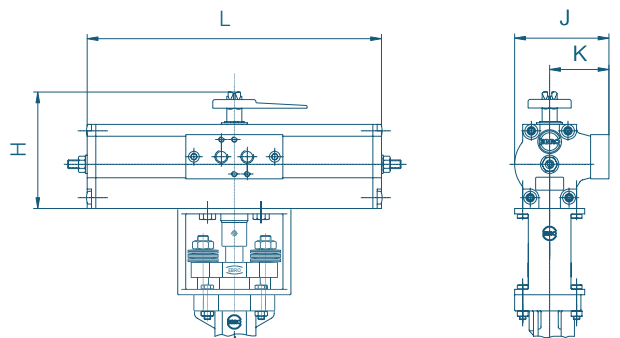

SWITCH BOX SERIES MSK/NSK

MSK: Switch Box with integrated micro limit switches.
NSK: Switch Box with integrated proximity switches.

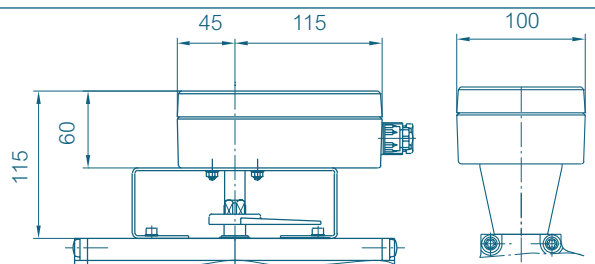

Subject to change without notice.

ACTUATORS HP 114-E

WORM GEAR FOR PTFE-SEAT

DN [mm]	Size [in]	Gear	H	J	K	L	Weight [kg]
50-125	2-5	Size II	89	39	125	159	1,4
150	6	Size III	129	47	200	202	2,3
200	8	Size IV	129	60	200	252	2,8

FOR INCONEL-SEAT

DN [mm]	Size [in]	Gear	H	J	K	L	Weight [kg]
50-100	2-4	Size II	89	39	125	159	1,4
125-150	5-6	Size III	129	47	200	202	2,3
200	8	Size IV	158	76	250	280	6,3

The dimensioning of actuators refers to an operating pressure of 10 bar.

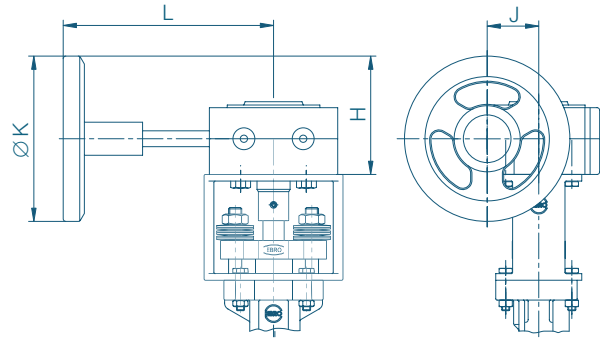

ELECTRIC ACTUATOR FOR PTFE-SEAT

DN [mm]	Size [in]	Actuator Type	H	J	K	L	M	Weight [kg]
50-125	2-5	E 65	233	172	80	139	119	7,0
150-200	6-8	E 110	251	245	125	139	134	14,0

FOR INCONEL-SEAT

DN [mm]	Size [in]	Actuator Type	H	J	K	L	M	Weight [kg]
50-100	2-4	E 65	233	172	80	139	119	7,0
125-200	5-8	E 110	251	245	125	139	134	14,0

The dimensioning of actuators refers to an operating pressure of 10 bar.

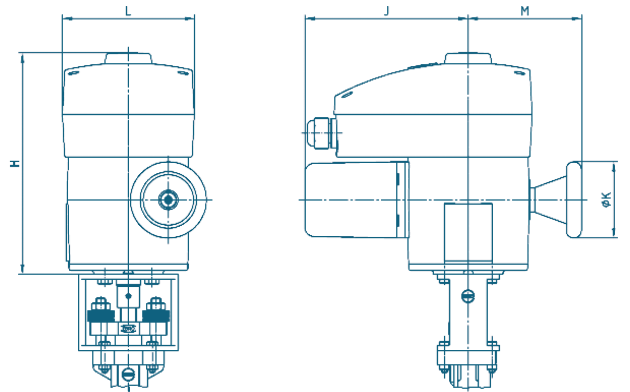

Subject to change without notice.

HIGH-PERFORMANCE BUTTERFLY VALVE HP 114-E

TORQUE

- The values specified are based on the initial breakaway torque. (disc disengages from seat, torque than drops).

DN [mm]	Size [in]	Operating Pressure			
		10 [bar]		16 [bar]	
		R-PTFE	Inconel	R-PTFE	Inconel
50-65	2-2½	27	35	28	42
80	3	28	55	30	65
100	4	51	90	61	100
125	5	63	150	83	172
150	6	125	170	136	220
200	8	205	350	260	430

All Values in Nm

PRESSURE /TEMPERATURE DIAGRAM

- Pressure control line for GS-C25 body material and metal seat
- Pressure control line for 1.4408 body material and metal seat
- - - - - Pressure control line for R-PTFE-seat

The diagram illustrates the performance of the standard version of our valve type HP. Valves for higher pressure or deviating temperature are available upon request.

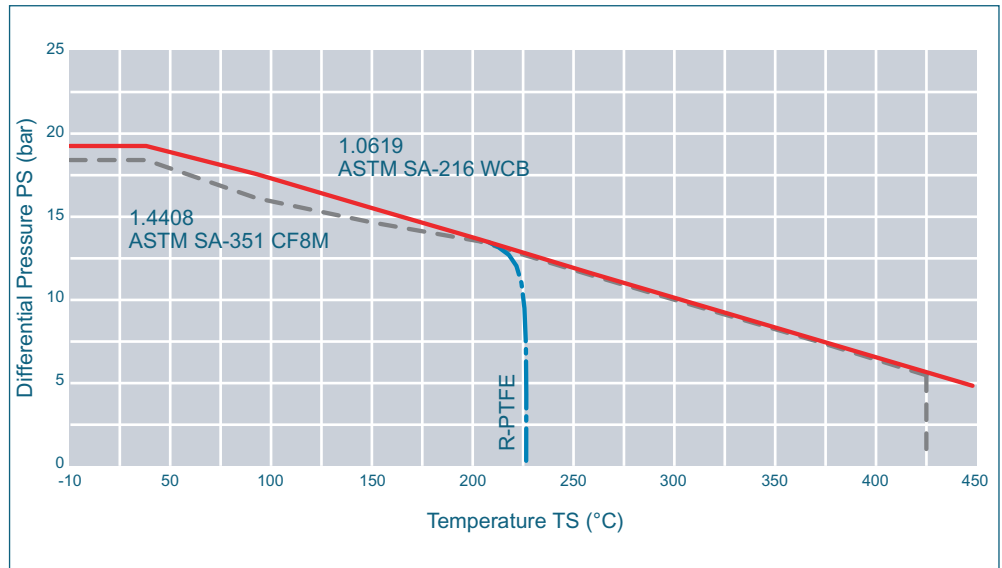

K_V-VALUES

- The K_V-value (m³ per hour) is the flow of water at a temperature of 5 °C to 30 °C (41 °F to 86 °F) Δp of 1 bar.

- The K_V-values specified are based on tests carried out by the Delft Hydraulics Laboratories, the Netherlands.

- Permissible velocity of flow V_{max} 4,5 m/s for liquids and V_{max} 70 m/s for gases.

For further values, please contact our engineers.

DN [mm]	Size [in]	Opening angle α							
		20°	30°	40°	50°	60°	70°	80°	90°
50	2	3	13	28	39	49	58	69	81
65	2½	3	13	29	41	52	61	72	84
80	3	19	40	63	96	135	189	242	287
100	4	33	65	89	125	180	259	365	450
125	5	53	105	169	245	342	509	645	728
150	6	82	161	252	385	575	817	1010	1123
200	8	105	184	331	559	816	1217	1795	1921

Subject to change without notice.