

VÁLVULA BORBOLETA COM FLANGE DUPLO F012-A

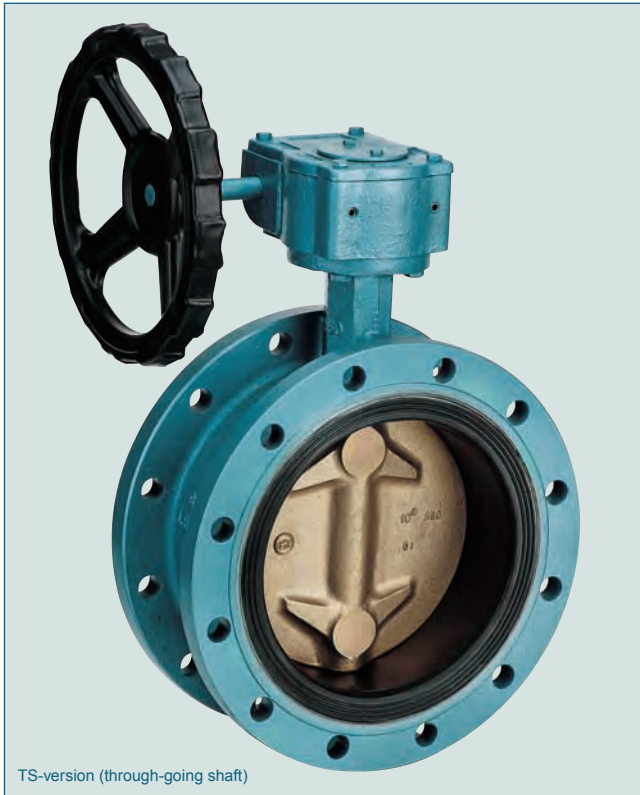

TS-version (through-going shaft)

The double flanged design is suitable for high pressure loading and is excellently suited for use in heavy industry, shipbuilding and waterworks.

TECHNICAL DATA

Nominal diameter:	DN 50 – DN 1200
Face-to-face:	EN 558 Series 13 ISO 5752 Series 13 API 609 Table 2C BS 5155 short NF E 29-305.1
Flange accommodation:	DIN 2501 PN 6/10/16 ANSI B 16.5, Class 150 MSS SP44 Class 150 AWWA C 207 AS 2129 Table D and E BS 10 Table D and E JIS B 2211-5 K JIS B 2212-10 K
Flange Surface Design:	DIN 2526, Form A-E, ANSI RF
Top flange:	EN ISO 5211 NF E 29-402
Marking:	DIN EN 19
Tightness check:	DIN 3230 T3 BO, BN (Leakage Rate 1) ISO 5208, Category 3 API 598 Table 5 ANSI B 16-104, Class VI
Temperature range:	-20 °C to + 160 °C (depending on pressure, medium and material)
Operating pressure:	max. 16 bar
Differential pressure:	max. Δp 16 bar
Vacuum:	0,2 bar absolute (depending on medium and temperature)

FEATURES

- Absolutely tight sealing with flow in either direction
- The valve body and disc are accurately machined which results in low operating torque and long service life and reliability.
- Triple shaft bearings prevents shaft deflection and guarantees optimum guidance even after many years of operating service.
- Can be disassembled, material-specific recycling possible.
- Single flange mounting is possible.
- Can be installed in any desired position.
- Maintenance-free
- Fully repairable valve

GENERAL APPLICATIONS

- Offshore
- Water and wastewater technology
- Shipbuilding



DOUBLE FLANGED BUTTERFLY VALVE F 012-A

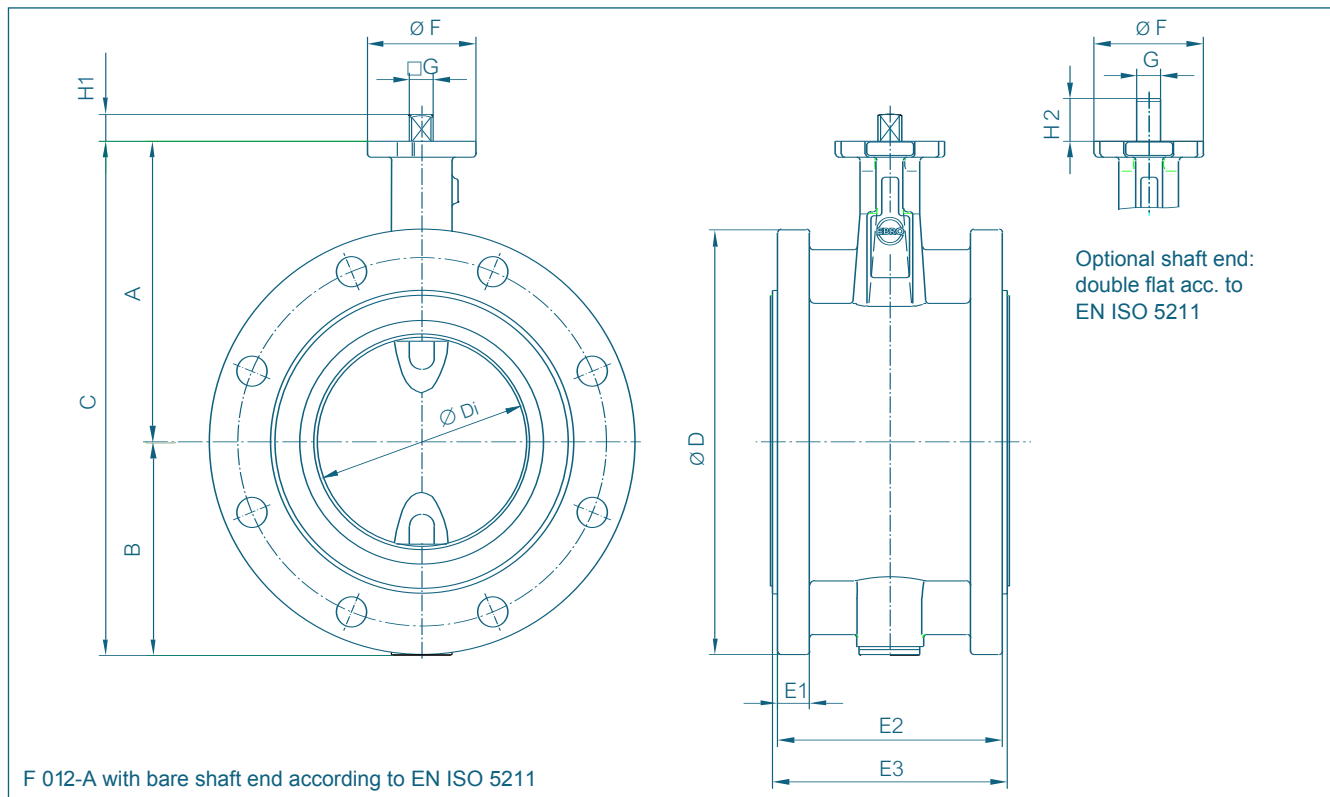

DN [mm]	Size [in]	Dimensions [mm]													Weight [kg] (GGG-40)	
		A	B	C	Di	D	E1	E2	E3	F	Flange	G	H1	H2	splitted Shaft	TS- Shaft
50	2	126	84	210	48,5	165	15	102	108	54	F04	11	12	19	9,3	-
65	2½	134	93	227	63,5	185	15	106	112	54	F04	11	12	19	10,1	-
80	3	157	104	261	78,5	200	17	108	114	65	F05	14	16	25	12,2	12,7
100	4	167	115	282	98,5	229	17	121	127	65	F05	14	16	25	16,1	16,7
125	5	180	127	307	123,5	254	19	134	140	65	F05	14	16	25	24,0	24,6
150	6	203	150	353	148	285	19	134	140	90	F07	17	19	30	29,0	30,5
200	8	228	176	404	199	343	21	146	152	90	F07	17	19	30	39,1	40,9
250	10	266	212	478	248	406	23	159	165	125	F10	22	24	39	61,2	64,2
300	12	291	237	528	296	483	24	170	178	125	F10	22	24	39	81,4	84,2
350	14	332	269	601	338	533	24	182	190	150	F12	*	*	-	107,0	112,6
400	16	363	314	677	388	597	28	208	216	150	F12	*	*	-	142,0	147,8
450	18	397	335	732	430,5	640	33	214	222	175	F14	*	*	-	183,0	188,0
500	20	437	405	842	494,5	710	40	223	229	210	F14/F16	*	*	-	233,0	240,0
550	22	456	435	891	540	750	40	219	229	210	F16	*	*	-	268,0	285,0
600	24	502	465	967	590	840	40	257	267	300	F16/F25	*	*	-	303,0	330,0
700	28	581	507	1088	680	920	41	286	292	300	F16/F25	*	*	-	407,0	460,0
800	32	630	556	1186	780	1050	47	312	318	300	F25	*	*	-	604,0	624,0
900	36	696	617	1313	880	1178	47	320	330	300	F25	*	*	-	745,0	787,0
1000	40	771	675	1446	980	1280	47	404	410	350	F30	*	*	-	942,0	1090,0
1200	48	905	810	1715	1170	1510	55	460	470	350	F30	*	*	-	-	1400,0

* according to the mounted actuator

Subject to change without notice.

ACTUATORS F 012-A

HAND LEVER

DN [mm]	Size [in]	Hand Lever	F	H	L	Weight [kg]
50- 65	2-2½	Size II	54	70	155	0,10
80-125	3-5	Size II	65	80	195	0,15
150-200	6-8	Size III	90	100	276	0,50

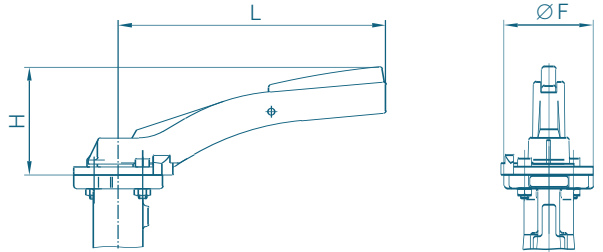

WORM GEAR

DN [mm]	Size [in]	Gear	H	J	K	L	Weight [kg]
50-65	2-2½	Size I	89	39	125	152	1,9
80-125	3-5	Size II	89	39	125	159	1,4
150-200	6-8	Size III	129	47	200	202	2,3
250	10	Size IV	129	60	200	252	2,8
300-350	12-14	Size V	158	76	250	280	6,3
400-450	16-18	Size VI	228	90	356	322	16,0
500	20	Size VII	278	123	457	406	30,5
550-600	22-24	Size VIII	355	154	610	466	45,0
700-800	28-32	Size XIV	295	54	457	466	65,0
900	36	Size XV	294	97	457	498	104,0
1000	40	Size XVI	253	237	356	558	186,0
1200	48	Size XVII	323	292	457	647	262,0

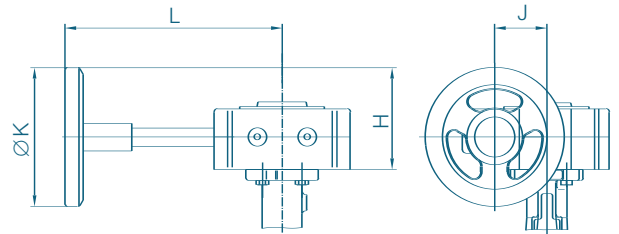

The dimensioning of actuators refers to an operating pressure of 10 bar.

ELECTRIC ACTUATOR

DN [mm]	Size [in]	Actuator Type	H	J	K	L	M	Weight [kg]
50-150	2-6	E 65	233	172	80	139	119	7,0
200-250	8-10	E 110	251	245	125	139	134	14,0
300-350	12-14	E 160	239	279	198	139	157	25,0
400-500	16-20	E 210	276	369	315	139	215	40,0

The dimensioning of actuators refers to an operating pressure of 10 bar.

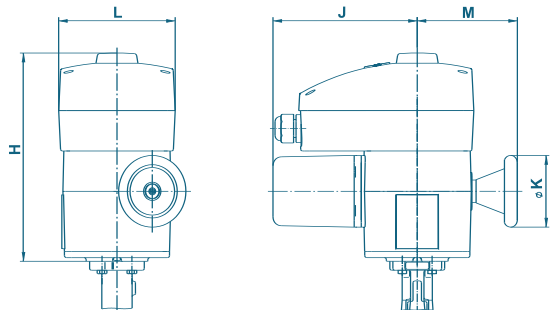

Other Actuators: See Documentation of the Manufacturer.

Subject to change without notice.

ACTUATORS F 012-A

PNEUMATIC DOUBLE ACTING

DN [mm]	Size [in]	Actuator Type	H	J	K	L	Weight [kg]
50-65	2-2½	EB4	96	74	49	145	1,1
80-125	3-5	EB5	108	88	55	174	1,7
150	6	EB6	123	103	62	208	2,6
200	8	EB8	136	115	68	250	4,3
250-300	10-12	EB10	155	135	79	312	6,8
350-450	14-18	EB12	182	159	94	367	12,0
500	20	EB265	232	152	76	390	18,0
600-700	24-28	EB270	278	220	110	445	32,0
800-900	32-36	EB280	278	220	110	600	42,0

The dimensioning of actuators refers to the following operating conditions:

Control air Pressure: 6 bar

Operating Pressure: DN 50 - DN 300 10 bar

DN 350 6 bar

DN 400 - DN 900 3 bar

Dimensioning for other conditions: upon request

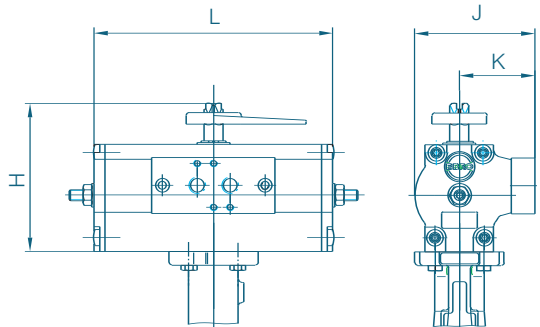

PNEUMATIC SPRING RETURN

DN [mm]	Size [in]	EBF Actuator	H	J	K	L	Weight [kg]
50-100	2-4	EB5	108	88	55	273	3,0
125	5	EB6	123	103	62	326	5,0
150	6	EB8	136	115	68	389	7,7
200	8	EB10	155	135	79	526	14,3
250-300	10-12	EB12	182	159	94	658	25,4
350-400	14-16	EB270	278	220	110	655	45,0
450-600	18-24	EB280	278	220	110	1020	68,0

The dimensioning of actuators refers to the following operating conditions:

Control air Pressure: 6 bar

Operating Pressure: DN 50 - DN 300 10 bar

DN 350 6 bar

DN 400 - DN 900 3 bar

Dimensioning for other conditions: upon request

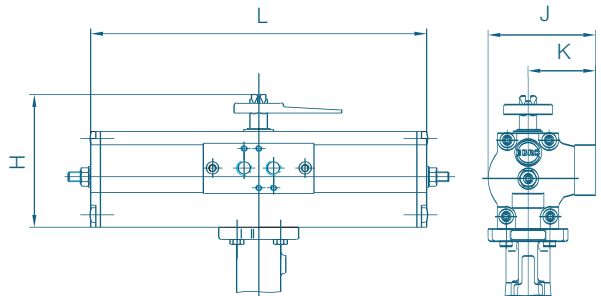

SWITCH BOX SERIES MSK/NSK

MSK: Switch Box with integrated micro limit switches.

NSK: Switch Box with integrated proximity switches.

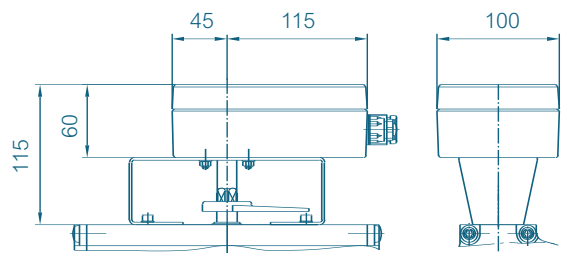

Other Actuators: See Documentation of the Manufacturer.

Subject to change without notice.

DOUBLE FLANGED BUTTERFLY VALVE F 012-A

MATERIAL SPECIFICATION AND PARTS LIST

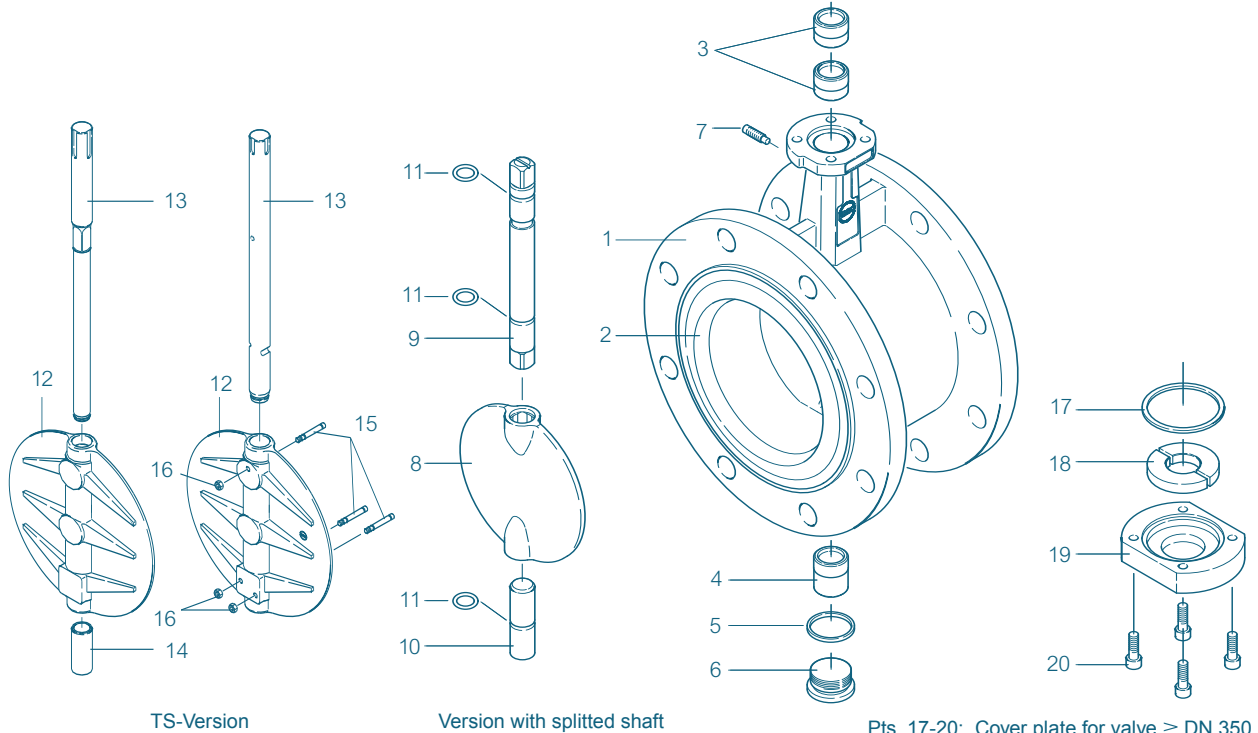

Pts. 17-20: Cover plate for valve ≥ DN 350

Pt.	Bezeichnung	Material	Material-No.	ASTM	Pt.	Description	Material	Material-No.	ASTM
1	Body				9/10	Shafts			
	Nodular Cast Iron	GGG-40	0.7040	60-40-18		Stainless Steel	X14CrMoS17	1.4104	430F
	Carbon Steel	GS-C25	1.0619	WCB			X5CrNiMo17-12-2	1.4401	316
2	Seat						Hastelloy	2.4883	Hastelloy
	NBR	Acrylonitrile butadiene rubber				Bronze	CuAlNiBZ	2.0975	
	EPDM	Ethylene propylene caoutchouc			11	O-ring			
	CSM	Chlorsulphonated polyethylene				NBR	Acrylonitrile butadiene rubber		
	FPM	Fluorocarbon caoutchouc				FPM	Fluorocarbon caoutchouc		
	VSI	Silicon rubber			12	TS-disc			
3/4	Bearing bush					Nodular Cast Iron	GGG-40	0.7040	60-40-18
	Bronze	RG 5				Stainless Steel	G-X6CrNiMo10-20	1.4408	CF8M
	Polyamide					Aluminium Bronze	CuAl10Ni	2.0975	C 95800
	PTFE					Coating	Halar, Rilsan		
5	Seal DIN 7603					Surface			
	Copper	Cu		Copper		Quality	electropolished, mirror finished		
6	Plug screw DIN 908				13	TS-shaft			
	Stainless Steel	11SMnPb30	1.0718 galv.	SAE12L14		Stainless Steel	X14CrMoS17	1.4104	430F
	Stainless Steel	G-X5CrNiMo19-11-2	1.4408	CF8M			X39CrMo17-1	1.4122	
							X5CrNiMo17-12-2	1.4401	316
7	Threaded pin DIN 915					Bronze	CuAlNiBZ	2.0975	
	Steel	45 H galvanized			14	Sleeve			
	Stainless Steel	X5CrNiMo17-12-2	1.4401	B8M		Stainless Steel	X5CrNi18-10	1.4301	304
8	Disc				15	O-ring			
	Steel	St52.3	1.0570	572-50		NBR	Acrylonitrile butadiene rubber		
	Stainless Steel	X5CrNi18-10	1.4301	304		FPM	Fluorocarbon caoutchouc		
		G-X5CrNiMo19-11-2	1.4408	CF8M					
		X2CrNiMo17-12-2	1.4404	316L	16	Retainin ring			
		X6CrNiMoTi17-12-2	1.4571	316Ti		Stainless Steel	X39CrMo17-1	1.4122	
		X2CrNiMoN22-5-3	1.4462	F51	17	O-ring			
		Hastelloy	2.4883	Hastelloy		NBR	Acrylonitrile butadiene rubber		
	Aluminium Bronze	CuAl10Ni	2.0975	C95800	18	Shaft retention			
	Coating	Halar, Rilsan				Bronze	RG 5		
	Surface				19	Cover plate			
	Quality	electropolished, mirror finished				Grey Cast Iron	GG-25	0.6025	40 B
					20	Screw			
						Steel	45 H galvanized		
						Stainless Steel	X5CrNiMo17-12-2		B8M
						Other materials upon request.			

Subject to change without notice.

DOUBLE FLANGED BUTTERFLY VALVE F 012-A

TORQUE

- The torque values specified (MD) are based on liquid and lubricant media.
 - Powdery (non-lubricant) media
Md x 1,3
 - Dry gases/high viscous media
Md x 1,2
 - The values specified are based on the initial breakaway torque.
 - Dynamic torque specification available upon request.
- Considering the dimensioning of actuators, please contact our engineers.

DN [mm]	Size [in]	Operating pressure			
		3 [bar]	6 [bar]	10 [bar]	16 [bar]
50	2	5	7	7	9
65	2 1/2	7	9	15	18
80	3	8	10	18	24
100	4	9	18	28	37
125	5	15	22	45	59
150	6	36	45	110	125
200	8	59	76	140	200
250	10	150	180	200	240
300	12	200	240	280	360
350	14	350	540	610	700
400	16	420	620	750	850
450	18	720	746	860	1500
500	20	900	1100	2255	3690
600	24	1050	1200	3000	5830
700	28	1560	2240	3450	8100
800	32	2070	3800	6600	11 200
900	36	2700	4900	7100	14 500
1000	40	4600	6780	11 500	24 400
1200	48	7800	12 000	21 000	44 000

K_V-VALUES

- The K_V-value (m³per hour) is the flow of water at a temperature of 5 °C to 30 °C (41°F to 86°F) at Δp of 1 bar.
 - The K_V-values specified are based on tests carried out by the Delfter Hydraulics Laboratories, the Netherlands.
 - Permissible velocity of flow
Vmax 4,5 m/s for liquids and
Vmax 70 m/s for gases.
 - The throttle function is linear at an angle 30° to 70°.
 - Avoid cavitation!
- For further values, please contact our engineers.

DN [mm]	Size [in]	Opening angle α°							
		20°	30°	40°	50°	60°	70°	80°	90°
50	2	1,2	8	13	22	38	50	65	85
65	2 1/2	2	9	22	42	77	115	170	215
80	3	8	24	50	95	150	240	330	420
100	4	13	28	65	130	180	340	550	800
125	5	26	65	130	230	350	530	870	1010
150	6	35	90	200	360	640	900	1350	2100
200	8	43	180	350	580	1000	1600	3000	4000
250	10	125	360	660	1100	1800	3100	5300	6400
300	12	200	550	1000	1600	2600	5000	7500	8500
350	14	350	780	1400	2400	4000	8000	10 800	11 500
400	16	490	1050	1800	3100	5500	11 000	12 000	14 500
450	18	510	1080	2040	3350	6100	11 500	14 600	20 500
500	20	520	1100	2200	3500	6200	12 000	15 100	21 000
600	24	750	1400	2800	5100	8800	14 000	22 000	29 300
700	28	770	1755	3260	5980	10 600	17 100	25 300	36 000
800	32	1200	2260	4550	8230	12 900	20 300	29 300	44 600
900	36	1540	2280	6030	10 500	17 600	29 200	42 150	59 000
1000	40	2200	3970	8300	14 480	24 000	37 100	60 300	81 500
1200	48	5050	7900	13 800	19 700	33 500	53 300	73 050	102 650